

**camstage**

31 Hedley Road  
St Albans  
Hertfordshire  
AL1 5JL

**t:** +44 (0) 1727 830 151  
**f:** +44 (0) 1727 855 993  
**e:** info@camstage.com  
**w:** www.camstage.com

## General Specifications

## T70 Track

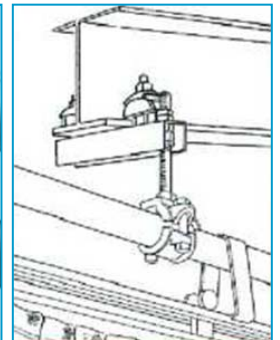
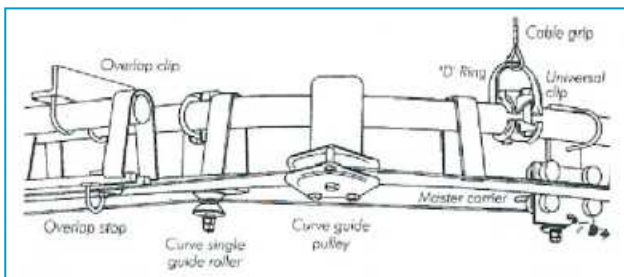
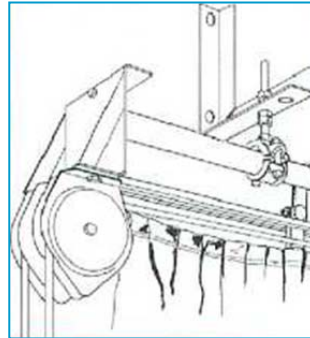
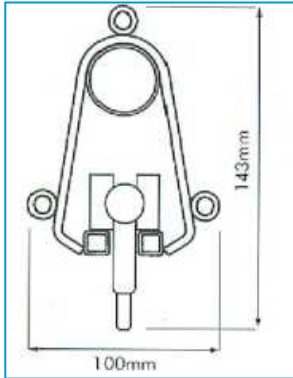

### Application

Theatres, Opera houses, Touring shows. Proscenium tracks, Cyclorama tracks, Tracks for hanging on counterweight sets and powered bars.

### Description

Steel fabricated track section.

### Finish

Black powder coated.

### Capacity

Wheeled runners 7kg capacity, one runner per 300mm. Optional ball raced wheeled carriers 9kg capacity.

Scenery carriers to 45kg capacity.

### Track forms

Straight: lengths 500mm - 3.00m.

Curved: sections from 1 m radius.

### Components

Wide range including: runners, pulleys, swivel arms and suspension systems.

### Configurations

Vast range using track joints and accessories.

### Operation

Handline, handwinch, electric controller or walkalong options. Rearfold options for hand or electric traverse systems.

### Fixing

Range of standard fixing kits for most situations with specials to order.

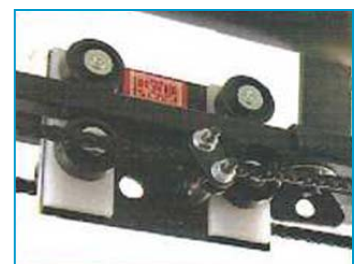
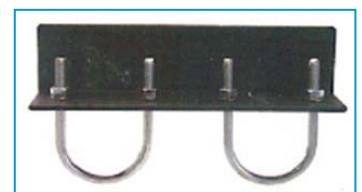
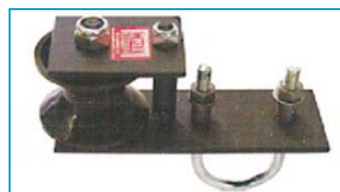

Please refer to our website: [www.camstage.com](http://www.camstage.com) for the current price list and COMPLETE TRACK KITS and all available components.